

**2014 NDIA GROUND VEHICLE SYSTEMS ENGINEERING AND TECHNOLOGY
SYMPOSIUM
VEHICLE ELECTRONICS AND ARCHITECTURE (VEA) TECHNICAL SESSION
AUGUST 12-14, 2014 - NOVI, MICHIGAN**

BRINGING PALADIN INTO THE 21st CENTURY

Bruce Bailey
BAE Systems
Endicott, NY

George Hamilton
TARDEC
Warren, MI

Mark R. Miller
Gordon Brinton
Eric Swartz
BAE Systems
York, PA

Paul Uetz
Eric Jochum
Dennis Regmont
PM-SPHS
Warren, MI

ABSTRACT

The M109A7/M992A3 Paladin Integrated Management (PIM) is a sustainment program designed to bring the M109 Family of Vehicles (FOV) up-to-date and extend the service life of the fleet. PIM consists of the sustainment and upgrade of two military tracked vehicles; the Paladin M109A6 Self Propelled Howitzer (SPH) and the M992A2 Carrier Ammunition, Tracked (CAT). The M109A7/M992A3 program is engineered to improve readiness, avoid component obsolescence, and increase sustainability. These changes will increase the performance of the M109A7/M992A3, eliminate obsolescence issues associated with supplying new parts to the M109A6 and M992A2, and ease the logistics burden within the Artillery Brigade Combat Team (ABCT) through commonality of spares parts. The PIM project has been a multi-phase project with development expected to continue into 2015.

INTRODUCTION

The M109A7 and M992A3 significantly enhances the reliability, mission maintainability, sustainability, and responsiveness of the M109A6 and M992A2 while establishing current and future commonality within the US. Army Armored Brigade Combat Team (ABCT). Beyond the Paladin Digital Fire Control System, previous upgrades hadn't altered much of the M109's 1950's chassis configuration [1]. To meet the

present day performance requirements as well as establishing a path to implementing future capability and growth initiatives, it was clear that the M109A6 needed to evolve from the legacy analog heterogeneous implantation to a scalable digital implementation. The platform needed to meet the following requirements:

- Provide an open and scalable architecture that would network various subsystems and Line Replaceable Units (LRUs)

- Seamlessly combine existing components with emerging technologies
- Maintain a reduced lifecycle cost through logistics support

The M109A6 Paladin Integrated Management (PIM) sustainment program electrical power management and vehicle health management requirements dictated the electrical/electronic architecture selected. The M109A6 Self-Propelled Howitzer (SPH) consisted of a 650A, 28Vdc belt-driven generator, four (4) 6T Maintenance Free (MF) batteries, thermal circuit breaker low voltage power distribution and discrete analog control/status for automotive/auxiliary/chassis vehicle systems.

Power Generation, Distribution and Management

Due to the howitzer's vehicle maximum electrical load of greater than 27kW and the Statement of Work (SOW) requirement, 'The M109A6 PIM electrical power generation shall have fifty percent (50%) reserve capacity for future growth at the time of Initial Operational Capability (IOC), for a total electrical power generation of 41kW. In order to meet this electrical power generation requirement dual 28Vdc generators would be necessary. This would have required twice the current volume, an innovative design to drive the dual alternator configuration and increased volume to accommodate the output cabling to the power distribution subsystem. These issues led the BAE Platforms & Services, York, PA electrical power generation and management design team to establish a joint interdivisional effort with BAE Systems, HybriDrive Solutions, in Endicott, NY for a different technical approach.

BAE Systems, HybriDrive Solutions was manufacturing Hybrid Electric Drive (HED) power electronic components for the transit bus

market and leveraged this technology to design/integrate a Common Modular Power System (CMPS) onto a Stryker vehicle platform which utilized a PTO-gear driven 72kW ISG. BAE Systems ES and TARDEC believed a CMPS was possible where all combat vehicles could utilize a common power architecture and common components where possible. The M109A7 electrical power generation and management design team recognized this as an opportunity to integrate a proven CMPS on the M109A7 vehicle platform. The BAE Systems interdivisional design team first had to review the power usage and power management capability gap analysis for the Stryker, M109A7, M992A3 and Bradley Fighting Vehicle (BFV) Family of Vehicles (FOVs). Electrical power generation system designs were then developed for each of the vehicle platforms. Finally, common power system components between the various platforms were identified leading to the M109A7/M992A3 electrical power generation, distribution and management system design.

The M109A7 Common Modular Power System consists of a 70kW High Voltage (HV) generator, four (4) Hawker Batteries, a 70kW generator inverter, two (2) 10kW Bi-Directional Converters, High Voltage Distribution Box (HVDB) and three (3) Vehicle Control and Distribution Modules (VCDMs) which provide Solid State Power Controller (SSPC) Cards for 28Vdc power distribution. The electrical power architecture includes a 610Vdc HV bus and 28Vdc Low Voltage (LV) bus providing input electrical power to the HVDB and VCDMs. A SAE J1939 CANbus provides electrical power control/status communication and the electrical power system diagnostics is communicated via GB Ethernet.

The 70kW HV generator and four (4) Hawker AGM Batteries provide the electrical power generation for the CMPS. The 70kW generator inverter inverts the generator AC voltage to +/-

305 (610Vdc) and the 10kW Bi-Directional Converters convert 610Vdc to 28Vdc. The 70kW generator inverter and two (2) 10kW Bi-Directional Converters provide the electrical power inversion and conversion for the CMPS. The 36.6kW HVDB and three (3) VCDMs provide the electrical power distribution for the CMPS. The 70kW generator provides the CMPS electrical power management which includes fault monitoring, load management, battery monitoring and electrical power control. Figure 1 shows the key components of the M109A7 power generation, distribution and management subsystems.

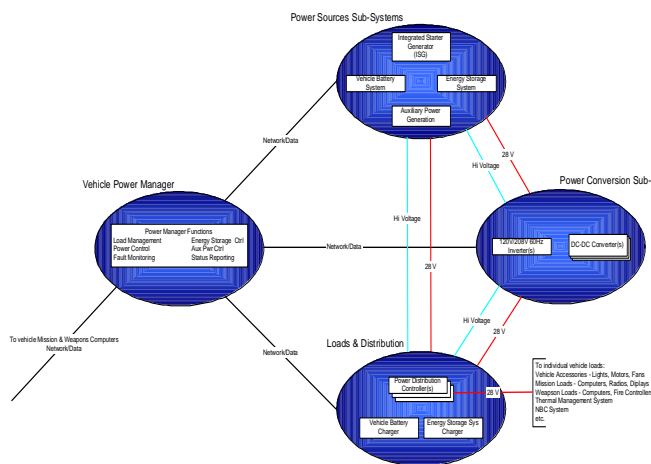

Figure 1- M109A7 power generation, distribution and management subsystems

Digital Backbone

The M109A6 SPH’s automotive, auxiliary, and electrical power subsystems were analog providing discrete input/output to the non-smart electrical Line Replaceable Units (LRU)s. The SOW required, ‘The M109A6 PIM shall have a Vehicle Health Management System (VHMS) which monitors and reports the health of the vehicle and its subsystems at a minimum to include Fire Control, Engine, Transmission, Power

Management and Electric Drive in accordance with the Heavy Brigade Combat Team (HBCT) VHMS Vehicle Segment Requirements Specification document ...’ and Power Management System SOW paragraph that states ‘The power management system shall manage electrical power distribution and utilization, monitor and protect the power system and loads, provide host vehicle electrical system status information to the crew and maintenance personnel’. These requirements resulted in the decision to implement a vehicle platform with a digital backbone.

Electric replaces Hydraulic

The M109A7 replaces the M109A6’s legacy hydraulically-operated elevation and azimuth drives with electric drive technology leveraged from the Future Combat Systems 155mm NLOS-C (Non-Line-of-Sight Cannon). Replacing the hydraulics with electrically operated drives drastically reduces maintenance and eases the logistics burden. Manual backups mitigate loss of electrical power. Additional maintainability and reliability improvements were gained by the replacement of the slip ring with a Cable Management System (CMS), an articulating conduit for the transfer of both high and low voltage power and networked communications between the chassis hull and cab.

ELECTRICAL/ELECTRONICS EVOLUTION FROM THE M109A6

Overview of High Voltage Power System and Components on the M109A7/M992A3

The electrical power of the PIM vehicle is separated into two systems as shown in Figure 2. The first system consists of equipment generating and utilizing high voltage power, which includes the Generator, Generator Inverter (GINV), High Voltage Distribution Box (HVDB), Bi-Directional

Converter (BiDi), Paladin Electric Servo Amplifier (PESA) and the Microclimate Conditioning System (MCS). The majority of the components are located in the Engine Compartment and the Weapons Controller Compartment. Various HV cables and motors are located in the crew compartment.

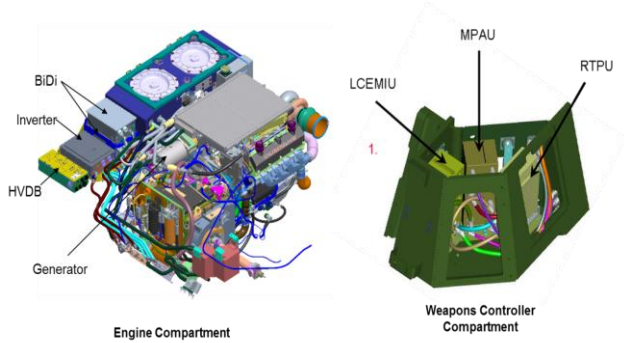

Figure 2- High Voltage Power Systems

The second electrical power system operates all other systems using 28V power. The 28V low voltage power system is dependent on the high voltage system, except for power from the batteries. All generated power begins as high voltage power, and is turned into low voltage power at the BiDi. The SPH has two BiDi's, and the CAT has one BiDi.

Due to the SOW requirements, 'Vehicle shall be capable of operating the Communications, Navigation, Automatic Fire Control Systems, exclusive of gun drives, for a minimum of 90 minutes... (Standby State Mode)' and 'Vehicle batteries shall have sufficient capacity to start the vehicle engine at the end of the 90 minute battery operation period', four (4) Hawker AGM Batteries with 1225 cold cranking amps were recommended from the battery trade to meet these requirements.

High Voltage Power System

The high voltage power system contains both 28V and 610VDC power. The 610VDC power is used to operate the equipment and the 28V power

is for circuits used to control and monitor the 610VDC power. Figure 3 shows the high level architecture of the high voltage power system.

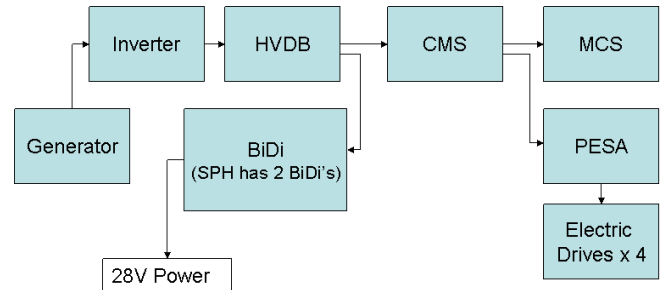

Figure 3 - High Voltage System Architecture

Generator

The high voltage power system is energized by a dedicated generator driven through a Power-Take-Off (PTO) unit mated to the powerpack, as shown in Figure 4. The generator creates three-phase AC power and uses permanent magnets. The output of the generator is variable and ranges from 74Vrms at idle to 450Vrms at max engine speed. The generator has sensors for temperature, and rotational position which are fed into the Generator Inverter. The SPH/CAT utilizes a 70kW integrated starter/generator. The generator does not use the integrated starter function.

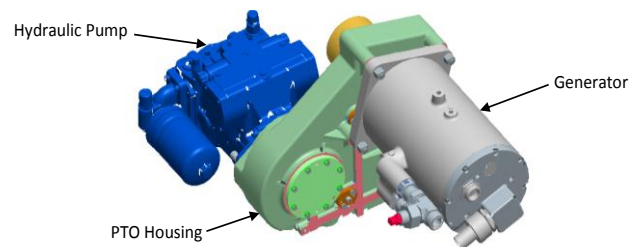

Figure 4 – Powerpack and Generator

Generator Inverter (GINV)

The Generator Inverter (GINV) converts the 3-Phase AC power from the generator to 610VDC. The 610VDC output is a direct current, two-wire system having a nominal output of 610VDC. The 610VDC is balanced with high impedance with respect to chassis ground in the GINV such that the positive output is nominally +305VDC and the negative output is nominally -305VDC. The GINV has ground fault detection capability for the high voltage bus, diagnostic sensors for internal voltage, current and temperatures, as well as sensors for generator voltage, current, and temperature measurement. The GINV also provides over current, over voltage, and under voltage protection for the 610VDC high voltage bus. The GINV will disconnect or not allow high voltage power at its output if any sensors show that they are operating outside of the defined envelope.

The HV power from the GINV is also controlled by an interlock continuity loop circuit. The interlock circuit is continuous whenever the HV system is assembled properly. Once internal diagnostics are complete and the GINV is receiving power from the generator, the GINV will release its 610VDC power.

The high voltage power from the GINV is passed to the HVDB which distributes it to the rest of the system.

High Voltage Distribution Box (HVDB)

The HVDB takes power from the Inverter and distributes it to the BiDi, the PESA (SPH Only), and the MCS. In the SPH, the HVDB distributes power to two BiDi's. In the CAT, the HVDB distributes power to one BiDi.

The HVDB releases power to the PESA and to the MCS individually, when those devices command it. The command is initiated through interlock loop continuity which is controlled

within the PESA and the MCS. When the MCS and/or the PESA interlock loop are closed, the HVDB releases power to the respective system.

In addition to distributing power to the various systems, the HVDB also places current limiting fuses on each high voltage output terminal which protect against downstream short circuits. There are individual fuses on the high-side (+305V) as well as the low side (-305V) of each output. Additionally, if the HVDB does not react to a short circuit, there is still protection provided by the GINV.

The HVDB also includes an EMI filter for power traveling to the MCS and to the PESA.

Bi-Directional Converter (BiDi)

The SPH utilizes two BiDi's, the CAT uses one. The BiDi takes 610VDC power from the HVDB and converts it to 28V power in order to supply the low voltage components of the SPH/CAT.

Cable Management System (CMS) (SPH Only)

The high voltage circuit consists of equipment in the hull and in the cab of the SPH vehicle. The CMS links the two areas, allowing the cab to rotate in relation to the hull. Cables come into the cable management system from the hull disconnect bracket, and attach to the cab disconnect bracket when they leave the system.

The cable management system consists of a modified Igus E4 series 3838 Energy Chain running inside of a metal enclosure, as shown in Figure 5. The enclosure is not completely enclosed; there is an opening along the bottom surface which is the entry point for the cables. The electrical cables run within the interior of the Energy Chain which guide and protect them as the cab moves.

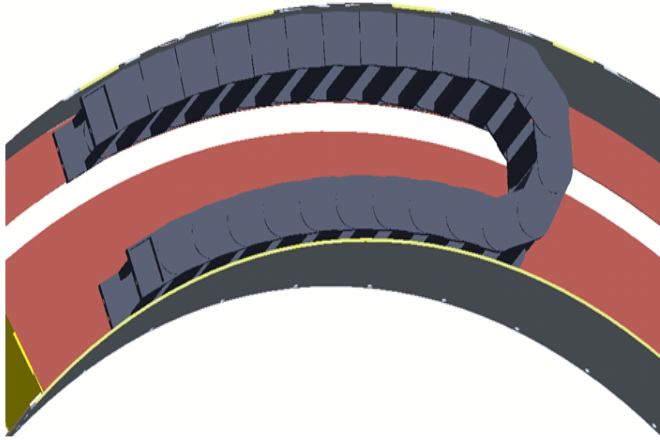

Figure 5 - Energy Chain system in the PIM SPH enclosure (top of enclosure not shown)

High and low voltage power cables are both routed through the same Energy Chain. They are divided within the device by separators which keep the cables organized into channels. The cables are routed in the Energy Chain, and the energy chain moves in a manner such that the cables keep their arrangement to each other in the vertical plane. There are two High Voltage cables which run through the CMS. One cable serves the power to the PESA, and one cable serves the power to the MCS.

Paladin Electric Servo Amplifier (PESA)

The PESA is only on the SPH. The PESA distributes power to and controls the electric drives and rammer subsystems. The PESA also interfaces with the vehicle's fire control system.

Three units together create the PESA. The units are the Load Control & EMI Filter Unit (LCEMIU), the Motor Power Amplifier Unit (MPAU), and the Real Time Processing Unit (RTPU). The three boxes are arranged in the Weapon Controller Compartment, which is at the forward driver-side of the cab, as shown in Figure 6.

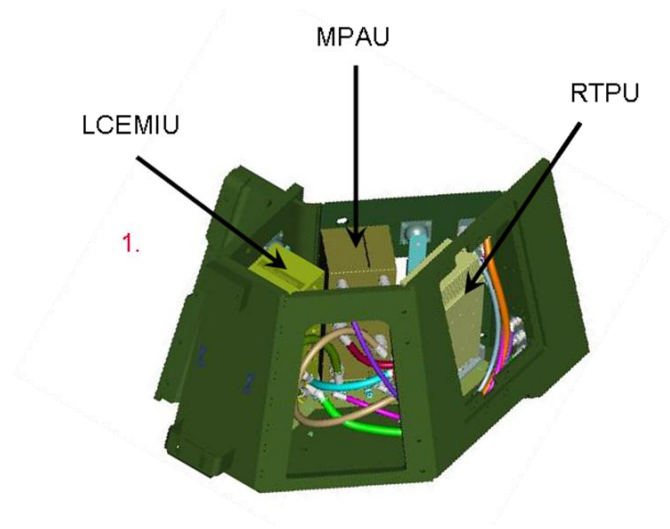

Figure 6- PESA components as arranged within the Weapon Controller Compartment.

The PESA has load fault protection. The PESA provides over current protection for 610VDC differential mode currents and Common Mode currents. For safety purposes, the PESA interfaces with two separate emergency stop (E-Stop) switches. These switches provide E-Stop capabilities to remove high voltage to the PESA and to all drive mechanisms controlled by the PESA. The PESA interfaces with the CAB Drives Control Box where it can receive movement commands from the PDFCS or manual joysticks.

Microclimate conditioning system (MCS)

The Microclimate Conditioning System (MCS) is located on the left side and rear in the Gunner's station. Under normal situations, cooling systems affect environmental temperature conditions by a process known as heat exchange whereby heat is either removed or added to either heat or inversely "cool" air in a room.

The MCS is enclosed in a separate compartment, which is only accessible from the exterior of the vehicle. Once the exterior cover is opened, all HV cables and components are housed within grounded enclosures.

High Voltage Safety and the M109A7/M992A3

The high voltage systems of the SPH and CAT are capable of mitigating hazardous situations and protecting equipment and personnel from potential injury. These safety feature capabilities include aspects of ground fault protections, interlocks, high voltage/energy discharge protection, awareness, and training. In addition, the HV components are designed to withstand partial and total submersion.

These design requirements are intended to prevent inadvertent or accidental contact with hazardous voltages or to prevent damage or injury from the uncontrolled release of electrical energy during normal operation, maintenance, and abnormal operating conditions.

Ground Fault Protections

Ground fault protection systems have been designed into the Generator Inverter (GINV) and PIM Electric Servo Amplifier (PESA). Multiple layers of insulation, shielding and conduit if compromised help trigger a ground fault condition and safely shut down HV/HE in the system

The GINV high voltage output is a two wire source which floats but is centered with respect to chassis ground or 0V (centered by balancing resistors in the GINV). Its differential output voltage is regulated to be 610VDC resulting in its positive output being at a potential of +305V with respect to chassis ground and its negative output being at a potential -305V with respect to chassis ground.

The GINV defines a ground fault as a shift in the +/-305V high voltage outputs with respect to chassis ground (0V). The differential voltage is monitored to account for normal regulation tolerance of the 610VDC high voltage bus when

setting the trip point for the -305V output to chassis ground threshold measurement.

When a ground fault to chassis occurs, it is expected to pull the faulted output toward chassis ground or 0V. In this case the potential of the opposite line would be pulled away from 0V in order to maintain the 610VDC nominal differential regulation point of the GINV output (Example, if the -305V line has a ground fault, it should go toward 0V and the opposite line should go toward +610V). Therefore by monitoring the -305V output with respect to chassis ground a shift in either +/-305V output caused by a ground fault to chassis ground can be detected.

Upon detection of a ground fault the GINV will shut down and disconnect from the 610VDC high voltage output in less than ~23.5mS.

High Voltage Interlock Circuits

Hazardous Voltage electrical circuits are provided with an appropriate set of Automatic disconnects, Manual disconnects and or Interlocks to prevent inadvertent contact with the hazardous voltage. There is a low voltage interlock wire within the cables that carry HV power between the HV components. If broken, the Low Voltage (LV) interlocks in multiple subsystems shuts down HV from the GINV.

Interlock circuits are utilized as a safety feature. By incorporating an interlock circuit within the same cables used for high voltage power, the system can monitor the high voltage cables and connections. Discontinuity in the interlock circuit will show if a high voltage cable has been severed or is not connected. A discontinuity in the interlock circuit will remove power or prevent power from being applied.

Since a break in the interlock circuit indicates an unsafe condition and therefore removes power,

other safety features (emergency stops, equipment enclosures) are integrated into the interlock circuit which will also break it.

All HV cables on the SPH/CAT are interlocked. If any connector is unplugged during operation the HV system will at a minimum shut down that portion of the HV:

- If the MCS HV cable is disconnected, the HVDB MCS contactor will open disconnecting power to the MCS
- If the PESA HV cable is disconnected, the HVDB PESA contactor will open disconnecting power to the PESA
- If any other HV cable between the GINV, HVDB and BIDI's are disconnected the:
 - GINV output contactor will open eliminating HV from exposed GINV pins/sockets
 - BIDI input contactors will open eliminating HV from exposed BIDI pins/sockets
 - HVDB will bleed the HV down to <50V in less than 2 seconds from exposed HVDB pins/sockets
 - The only voltage that will not shut off is the generator 3 phase output, if disconnected the HV system will shut off but AC HV will still be present on generator output sockets.

High Voltage/Energy Discharge Protection

When a short circuit occurs within the HV system (+305 line touching -305 line) an arc flash can occur. Temperatures during an electrical arc are severely high (up to 35000°F). This heat causes a sudden expansion of air, and the vaporization of the conducting material. Personnel can be injured from the heat of the arc, or by the resulting sound and explosion caused by the rapid expansion of air and other materials. On the SPH/CAT, arc hazards are mitigated by the

limited energy within the system as well as the speed with which energy is safely shut down in the event of an arc.

Hazardous voltage cables, busses or wires routed within unoccupied vehicle spaces are insulated, firmly mounted, abrasion resistant and are designed and installed to minimize service personnel exposure to hazardous voltage circuits.

For hazardous voltage that is routed through crew and passenger compartments, the design includes metal HV cable guards that provide physical separation of the hazardous voltage wires from the personnel. The cables from the HVDB to the PESA and to the MCS are completely enclosed in cable guards while they are routed through the crew space. The cables from the PESA to the electric drives are enclosed for a significant majority of the area that they are routed through crew space.

The high voltage cable guard structure must be capable of protecting the crew from a worst case arc blast internal to the cable. The high voltage cable guard cannot rupture or cannot deform to the point of visually exposing the cable to the Crew. Modeling and simulation results show that 3/16" 5083-H321 or 5052-H32 aluminum material cable guard provides sufficient protection to the Crew in all cases. An arc blast event, with an equivalent 130 mg TNT, will not cause any permanent structural damage to the cable guard in either of the aluminum material options.

Awareness

All of the SPH/CAT high voltage wiring harness coverings (+/-300 600 VDC generator / motor wires and buss bars) are identified with the use of orange color conduit or sleeving/tubing and boots/transitions. Individual high voltage cables are also permanently marked with the voltage level as shown in Figure 7.

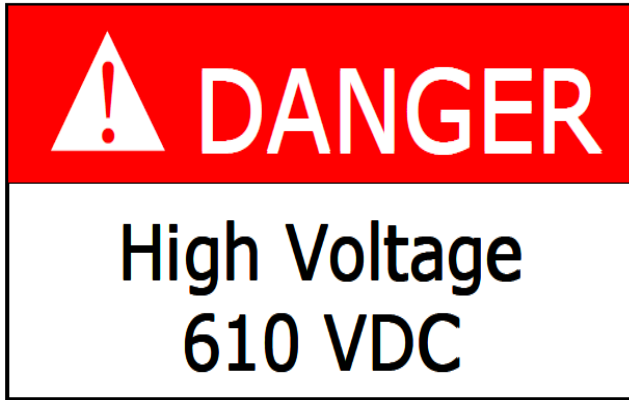

Figure 7 – High Voltage Warning on Electrical Wiring Harnesses

In addition, High Voltage components (LRUs) on the SPH/CAT include danger stickers as shown in Figure 8 to notify the crew and maintainers about the risk of electric shock.



Figure 8 – Danger sticker applied to High Voltage LRUs

Training

All operators/maintainers on the SPH/CAT must be trained regarding the HV system. Operators and maintainers must have verified knowledge of the system and the hazards present during the operation or maintenance of the vehicles.

Distributed vs. Federated Architecture

Although it was clear that a flexible architecture was needed, key decisions had to be made before holistically advancing to a digital architecture.

Through the years, the M109 had evolved primarily in a bottom-up fashion driven by the opportunities to bolt on new capability. The M109A7/ M992A3 design includes a new chassis, engine, transmission, suspension, tracks, and steering system which leverage common components from the Bradley Fighting Vehicle. The M109A7 / M992A3 vastly differs from its predecessor platforms with new vision of net-centricity, diagnostics, sustained growth potential, cost stewardship, and obsolescence avoidance all of which promoted a clean-sheet opportunity for top-down design. Top-down design encompasses the big picture for meeting legacy, current and future forecasted requirements.

Factors such as reliability, cost, ease of maintenance, and scalability all played a part in confirming the next generation architecture for the M109A7/M99A2A3. A primary design goal was to maintain high reliability and mission readiness, limit variables included within the critical path of mission critical capabilities. The architecture must cost effectively and reliably support the M109A7/M99A2A3's mission critical functions to shoot, move, and communicate. If vehicle power is lost, degraded mode and/or manual backups must be available to meet mission requirements. A secondary design goal was to leverage common components as much as possible to reduce the logistic burdens on the battlefield.

Federated/centralized options were considered but deemed cost prohibitive due to the LRU cost plus the cost of integrating additional wiring harnesses as compared with the distributed approach. The integration of multiple centralized LRUs also posed too many challenges to Size, Weight, and Power (SWAP) reduction initiatives.

Given the fact that a digital architecture was required for the M109A7 SPH an informal trade was conducted to determine a distributed digital architecture which supports the Victory Architecture Initiative or a Federated (Point Solution) digital architecture. The Vetronics Control and Distribution Module (VCDM) is the remote terminal module for the Distributed Architecture and the Digital Vehicle Distribution Box (DVDB) is the Point Solution for the Federated Architecture.

Table 1 below summarizes the advantages /disadvantages of a distributed digital architecture vs. a federated digital architecture.

Vetronics Control and Distribution Module (VCDM) Distributed Architecture vs. Digital Vehicle Distribution Box (DVDB) Federated Architecture Comparison	
Distributed Architecture (VCDM)	Federated Architecture (DVDB)
Modular and Flexible Design	Point and Vehicle Specific Design
Promotes Line Replaceable Unit (LRU) and Shop Replaceable Unit (SRU) Commonality and Building Block Design Approach	Does Not Promote LRU and SRU Commonality and Building Block Design Approach
Cost is Dependent on System Architecture Complexity and Partitioning of Functions PIM-SPH/CAT Distributed Architecture (VCDM) is less expensive than Federated Architecture (DVDB)	Routinely Less Expensive than Distributed Architecture PIM – SPH/CAT Federated Architecture (DVDB) is more expensive than Distributed Architecture (VCDM)
Allows For Good Design Practices to be Implemented (Example: Status and Control Processing should be isolated from Low Voltage High Power Distribution)	All functions are integrated into one LRU creating EMI/RFI, Thermal and Reliability Design Challenges (DVDB consolidates status/control processing, video processing, low voltage low power distribution and low voltage high power distribution, NATO slave connector functions into one LRU)
Designed to be interchangeable between vehicle locations and vehicle(s)	Point solution does not require interchangeability

Table 1 - Distributed digital architecture vs. a federated digital architecture

It was concluded by the M109A7 Vetronics Integrated Product Team (IPT) that a digital

distributed architecture utilizing the VCDMs as ‘plug and play’ modules was the right choice to meet the vehicle health management and electrical power management requirements. “Digitization” is facilitated by a combination of the new VCDM design and the Driver’s Smart Display Unit (SDU). The VCDMs distribute fault protected +28VDC power and provide operational status of the +28Vdc electrical loads.

Vetronics Control and Distribution Module (VCDM)

The key Line Replaceable Unit (LRU) for meeting much of the M109A7/M99A2A3 digital architectural requirements is the Vetronics Control and Distribution Module (VCDM). The VCDM is a modular LRU that provides networked point-of-load power distribution and management, serves as a digital bus gateway, and is a key enabler for diagnostics, fault detection and fault isolation. Each VCDM includes two VME 6U Solid State Power Controller (SSPC) Circuit Card Assemblies (CCAs) that continuously monitor power and provide fault protection. Each of the 16 channels on the SSPC CCA can independently distribute power to the respective loads via J1939 CAN Bus control. With a firmware update, SSPC channels can be paralleled to distribute power for higher current switching demands.

There are three VCDMs on the M109A7 and two VCDMs on the M99A2A3 vehicles. Each of these five VCDMs has the same hardware part number, has the same software version installed, and boots into its respective configuration based on the VCDM’s harness connector ID that instructs the VCDM to function per its respective location within the respective vehicle. This allows the same VCDM hardware to be used or swapped between different locations within the vehicle or between vehicles as needed.

Driver's Display

The Smart Display Unit (SDU) is a 10.4" display and computer integrated into one package. The SDU runs application software and is capable of performing video and graphics processing. The SDU includes gigabit Ethernet, CAN Bus, serial, USB, RS-170 video, RGB video, audio input and output, and a removable Solid State Disk (SSD). The SDU provides the driver with a virtual instrument cluster and serves as the main diagnostics interface to support fault detection and isolation.

MIGRATION OF THE SOFTWARE ARCHITECTURE

As illustrated in Figure 9 the legacy M109A6 contained some electronic components that had software was limited to the components related to the Fire Control System. As a result the on platform digital system design was limited to a few serial interfaces. The single Ethernet connection was only used for off-platform diagnostics. The M992A2 vehicle essentially contained no intelligent LRU's and had no digital architecture.

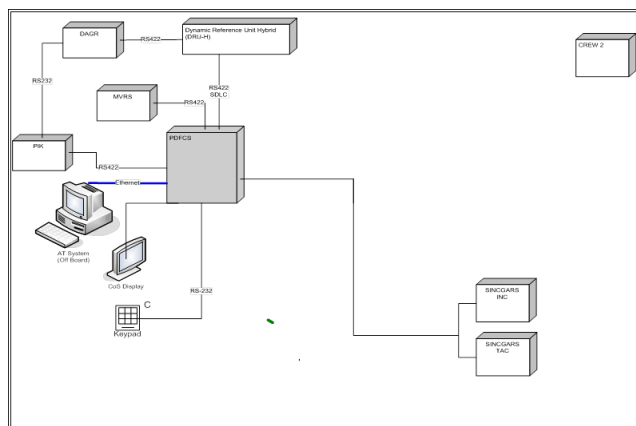

Figure 9 - Legacy Paladin M109A6 Architecture **Implementation of the digital backbone**

The M109A7 required an open and scalable architecture that provides the means for cost effective integration of present and future capability, implements and continuously improves diagnostics capability, and leverages commonality. The architecture required a digital backbone with proven reliability that leverages industry standards and builds-in mitigation against future obsolescence. The primary digital network selected for the M109A7 was the J1939 CAN bus. The J1939 CAN bus provides highly proven reliability (both historically and through practical application of prioritized determinism), provides scalable opportunity for up to 256 nodes which is much higher than practically could be used on the vehicle, and is leveraged by industry as a standard vehicle networking protocol. The J1939 CAN bus leverages thoroughly tested hardware and software components.

Phase 1 Software Development

Phase 1 of the program provided a significant increase in smart LRU's and provided the opportunity to allow the components to share information as needed. Figure 10 and Figure 11 illustrate the additions made to the M109A7 and M99A3 respectively. In order to achieve the goals of the program a significant number of electronics were added to both vehicles.

Overall the architecture is a distributed architecture with the CAT being a subset of the SPH. In looking at the respective architecture diagrams it can be noted that the CAT contains a subset of the components in the SPH. Most notably missing is anything related to the fire control system. Phase 1 also introduced the digital backbone of the vehicles. While there are still several components that rely on serial communications this was the start of the CAN Bus and Ethernet networks. While providing a distributed architecture there were two main hubs

of data interactions. The Vetronics Control and Distribution Module (VCDM) was the main hub for the CAN Bus and the Paladin Digital Fire Control System (PDFCS) provided the main hub for Ethernet data.

The CAN Bus is focused on the automotive, high power, and low power components using J-1939 standard. At this phase of the program the Ethernet is focused on the fire control system and the interface between the Fire Control Computer and the Electric Drive Drive and Rammer using XML for passing information.

Phase 2 Software Development

There were two major focus areas of Software Phase 2. One was to take the lessons learned from contractor and government testing of Phase 1 to improve the robustness of the overall vehicle system. The second was to introduce the Diagnostics and System Health (DASH) which would serve as a major component to support the Logistics efforts and ultimately the LOG Demo. Figure 12 and Figure 13 illustrate the updated M109A7 and M992A3 architectures respectively.

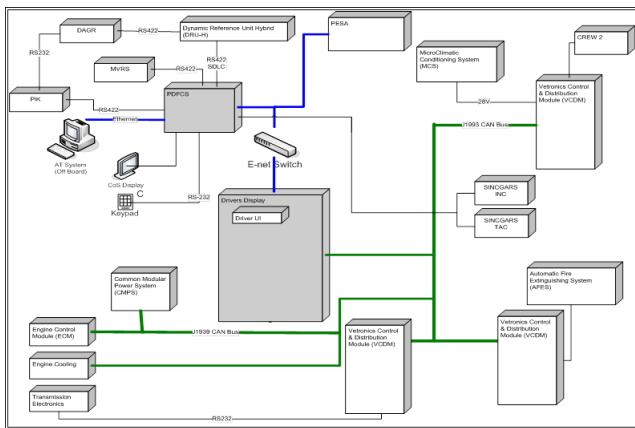

Figure 10 - Phase 1 M109A7 SW Architecture

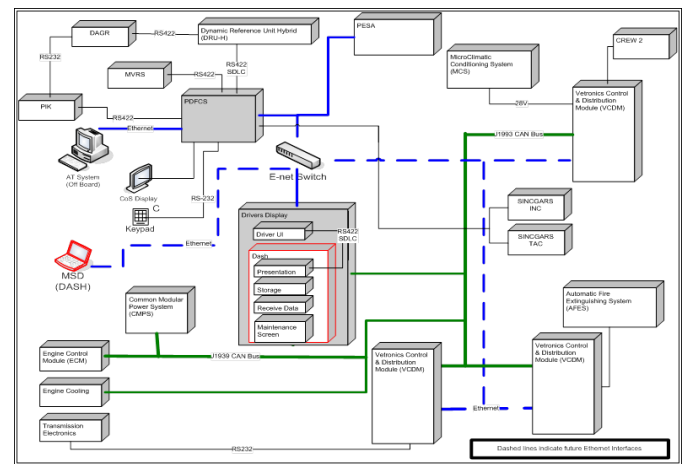

Figure 12 - Phase 2 M109A7 SW Architecture

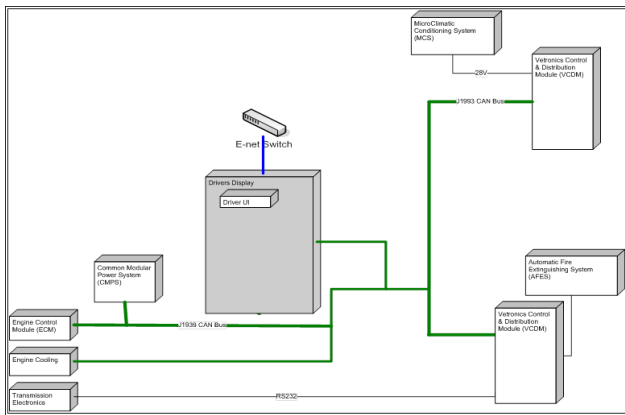

Figure 11 - Phase 1 M992A3 SW Architecture

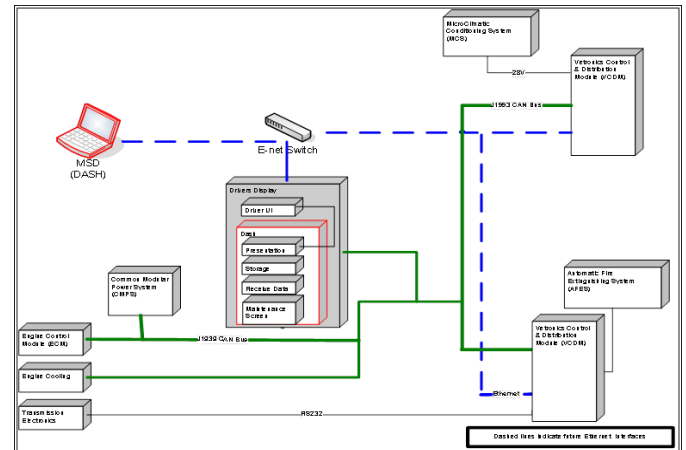

Figure 13 - Phase 2 M992A3 SW Architecture

The biggest addition was the expansion of the Ethernet bus as it provided the transport mechanism for the data necessary to support DASH. However since there are a large number of subsystems with no access to the Ethernet there needed to be a way to communicate from DASH to these other subsystems. The VCDM was originally designed to provide the solution to address this need.

The VCDM was designed with two microprocessors. One of the microcontroller boards was designated to perform all of the low voltage power distribution tasks. The second microcontroller board contained all the hardware necessary to support Ethernet communications as well as a dual port memory area to allow the exchange of data between the two. As a result the VCDM became the bridge between the CAN Bus and the Ethernet networks on the vehicle. This bridge network provides two way communications with the CAN Bus subsystems which allows DASH to send Interactive Built-In-Test (IBIT) commands to the various subsystems as well as receive the results.

Phase 3 Software Development

There were two major focus areas for SW Phase 3. One was to support any hardware changes made to the vehicle subsystems. The second was to build on DASH to provide significant expansion to the IBIT and provide an interface to the IETMs which would result in significant improvements in the fault isolation capabilities. Figure 14 and Figure 15 illustrate the updated M109A7 and M992A3 architectures respectively.

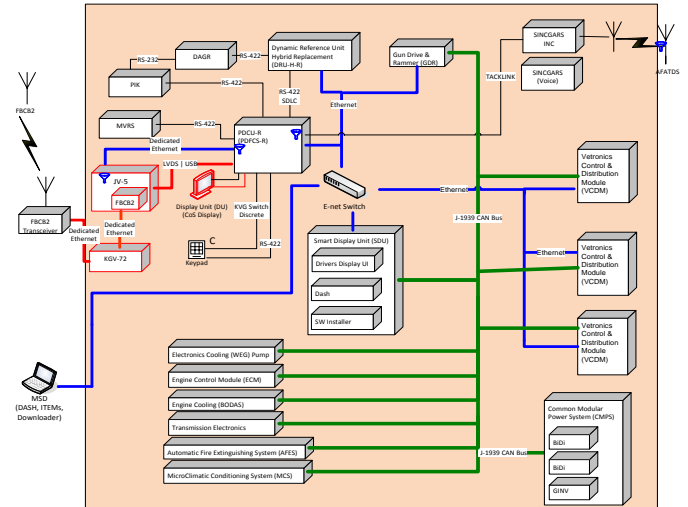

Figure 14 - Phase 3 M109A7 SW Architecture

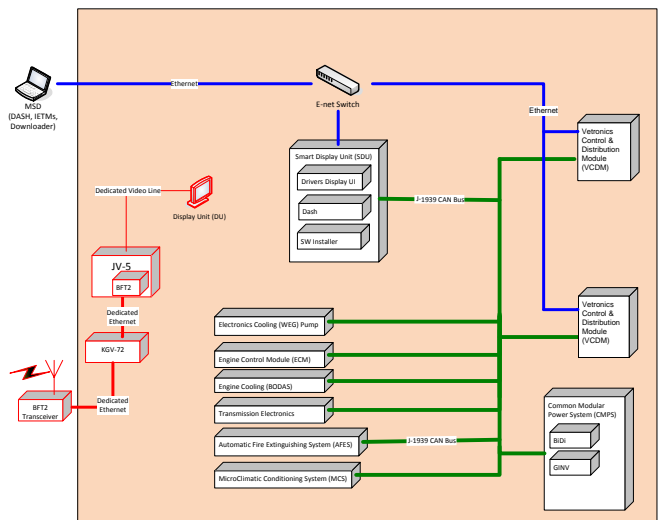

Figure 15 - Phase 3 M992A3 SW Architecture

Some of the significant changes to the architecture as part of SW Phase 3 were the transition of the Engine Control Module (ECM), Transmission Control Module (TCM), Automatic Fire Extinguishing System (AFES), and Water/Ethylene/Glycol (WEG) pump from a serial interface onto the CAN Bus. The ECM and TCM have also provided an Electronic Throttle Control design solution that replaced the existing hybrid electro-mechanical throttle design which was difficult to manufacture and support.

LESSONS LEARNED

This final overview section will identify some of the customer, program and technical issues encountered to design, integrate and test the M109A7 SPH CMPS and Digital Distributed Architecture.

High Voltage Safety

The M109A7 is the first Heavy Brigade vehicle to go into Low Rate Initial Production (LRIP) with a 70kW High Voltage system. A High Voltage training program needed to be created leveraging the Future Combat System (FCS) Hybrid Electric Drive (HED) documentation. The USG and industry had to develop new infrastructure, logistics and procedures to safely operate and maintain the M109A7 High Voltage CMPS.

Grounding and Bonding

Grounding and bonding is very important when designing and integrating a high voltage electrical power system. Special attention is required to make sure electrical bonds/grounds are properly installed to avoid DC and AC ground faults.

High Voltage Maturity

As a result of the addition of the new technology it was necessary to convince USG that the High Voltage CMPS electronic components were at a

high enough readiness level from a technical and manufacturing function to be fielded for the troops.

Information Assurance

The awareness of the threat due to computer security issues has grown significantly since the fielding of the M109A6. As a result what was acceptable for the previous vehicle is no longer acceptable in today's world. So, while the digital architecture provided a mechanism for the communication of information between the various subsystems and improved overall diagnostic capabilities it also then required additional work to insure that the proper security measures were satisfied.

Commonality

For each hardware commonality effort ensure that the LRU requirements and qualification tests encompass all necessary operational and environmental requirements (shock & vibration, hot and cold operational temperatures, radiated emissions etc.) for all vehicle types being considered.

REFERENCES

- [1]Defense Industry Daily Staff, "Have Guns, will Upgrade: The M109A7 Paladin PIM Self-Propelled Howitzer" Defense Industry Daily, 2014.